

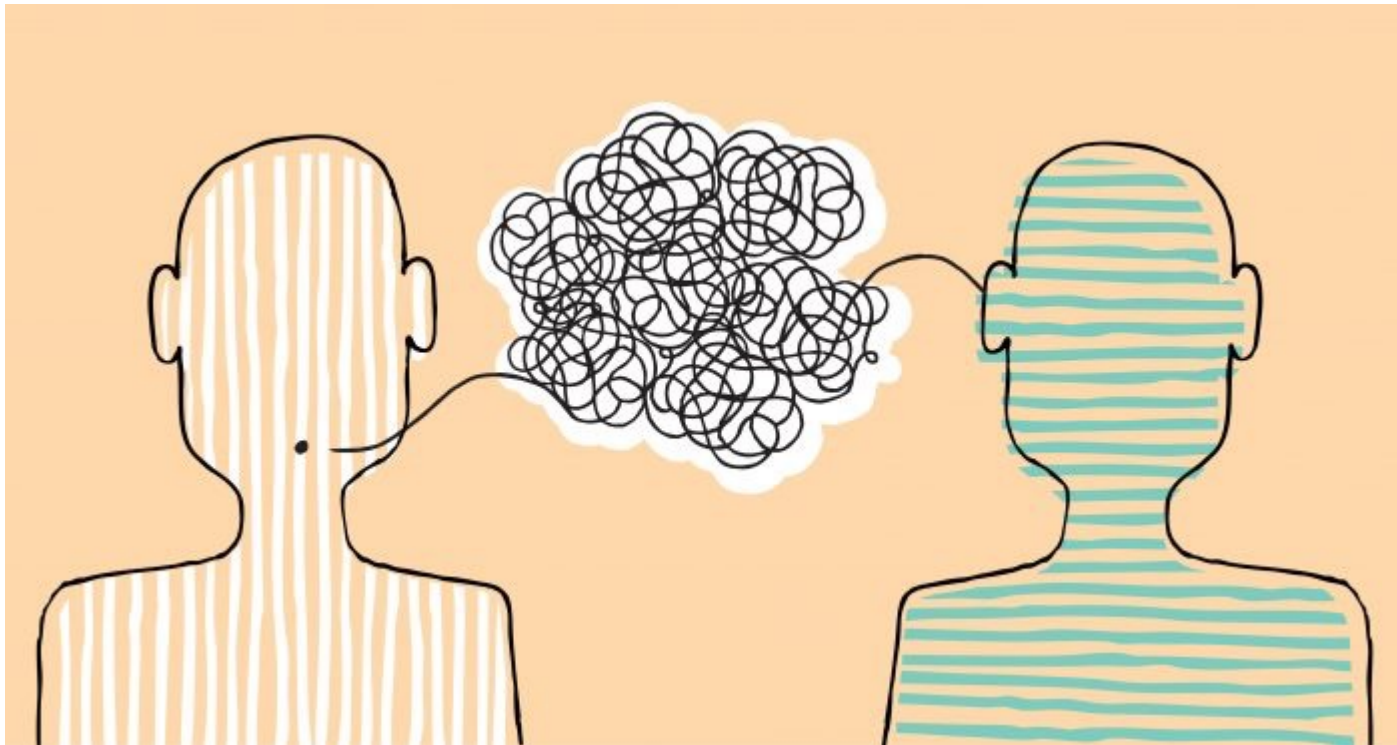

Do we have an agreement?

# Conceptual Pacts



# 1. Language games

Wittgenstein, Yo

# 2. Models of dialogue

Message model, interactive alignment, grounding

# 3. Conceptual pacts

Maze game, tangrams

## Wittgenstein



*“Slab!”*

- Words are defined only by their use, not their definition or meaning (Wittgenstein, 1953)
- A secret code that is written nowhere, known by none, and understood by all (Sapir, 1927)

# Language games

DARTMOUTH

Yo is a single-tap zero-character communication tool.

Yo is everything and anything, it all depends on you, the recipient and the time of the Yo.

Wanna say "Good morning"? just Yo.

Wanna say "Baby I'm thinking about you"? - Yo.

"Done with my meeting, come by my office" - Yo.

"Are you there?" - Yo

You determine the context.

We don't want your Email, Facebook, or Twitter. There is no search, no nothing. Just Yo.

Open the app, tap on a friend, that's it. The possibilities are endless!

**It's that simple, Yo.**

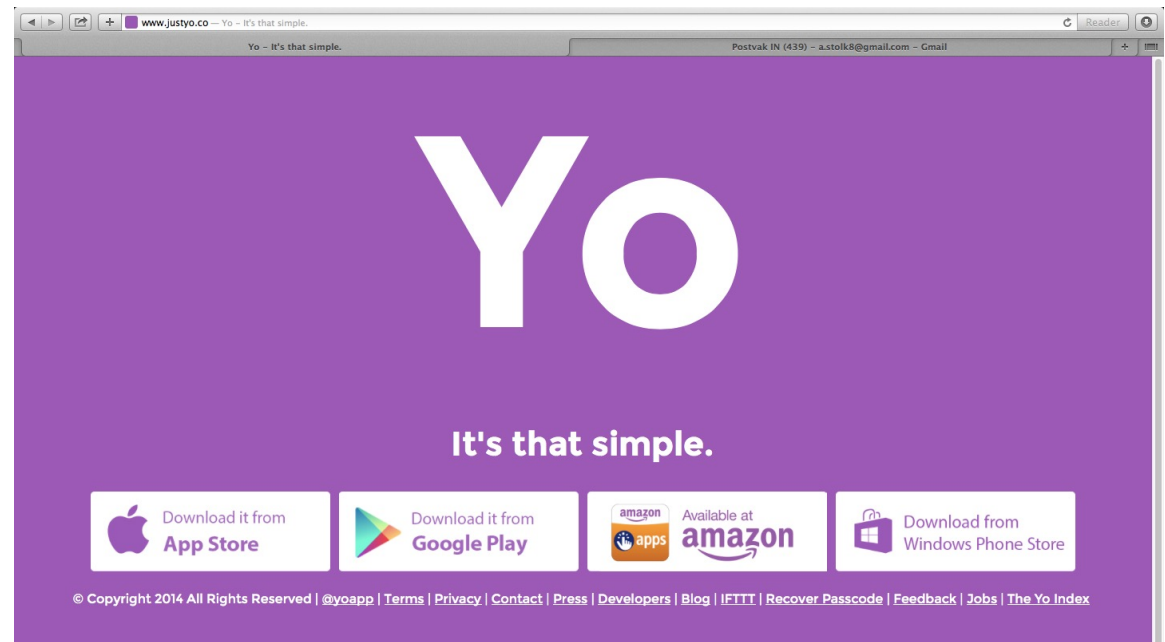
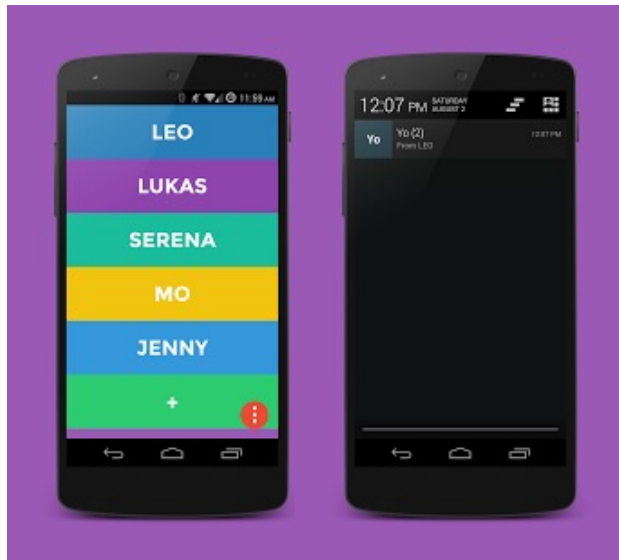

**The simplest and most efficient communication tool in the world**

# 1. Language games

Wittgenstein, Yo

# 2. Models of dialogue

Message model, interactive alignment, grounding

# 3. Conceptual pacts

Maze game, tangrams

# Message model

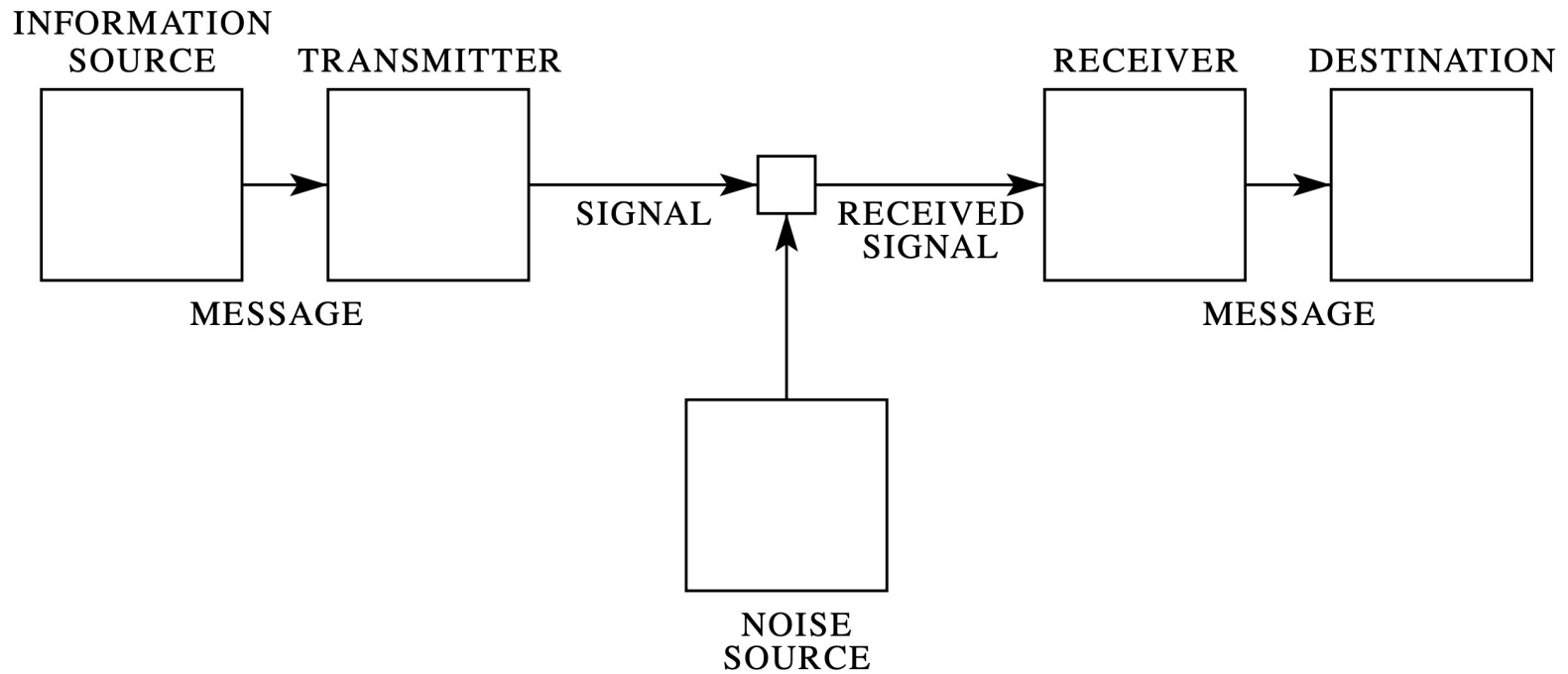

A Mathematical Theory of Communication

By C. E. SHANNON

Presupposes shared encoding/decoding rules for transferring information

# Interactive alignment model

Toward a mechanistic psychology of dialogue

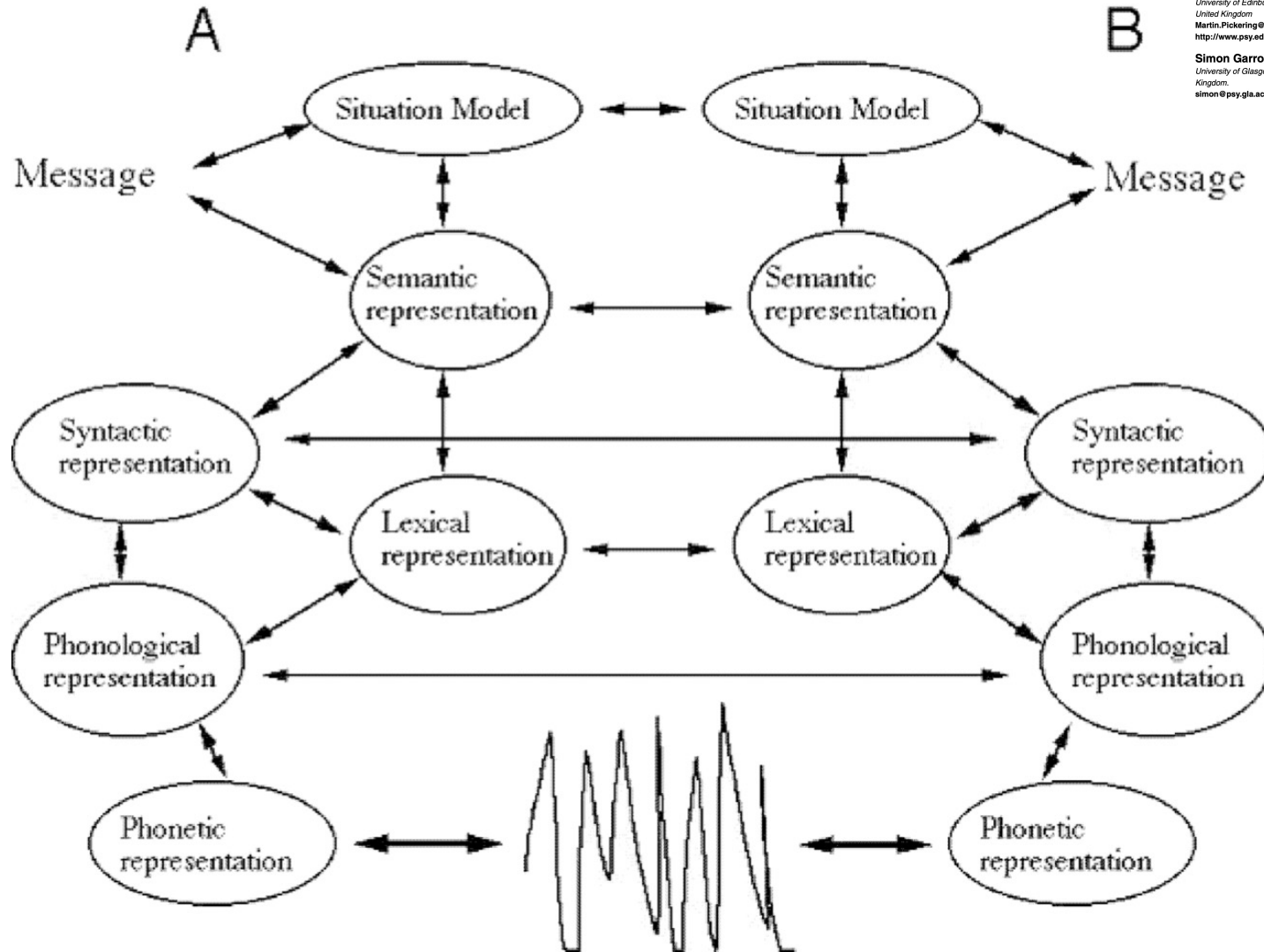

**Martin J. Pickering**  
University of Edinburgh, Department of Psychology, Edinburgh EH8 8JZ, United Kingdom  
Martin.Pickering@ed.ac.uk  
<http://www.psy.ed.ac.uk/Staff/academics.html#PickeringMartin>

**Simon Garrod**  
University of Glasgow, Department of Psychology, Glasgow G12 8OT, United Kingdom.  
simon@psy.gla.ac.uk <http://staff.psy.gla.ac.uk/~simon/>

Presupposes shared associations across levels and individuals



## Grounding model

...

Leah: um... then he gets punished or whatever?

Dale: what was that, a wreath or—

Leah: yeah it was some kind of brownny—

Adam: yeah it was some kind of straw thing or something

Leah: mhm

Dale: around his neck

Leah: so that everybody knew what he did or something?

Adam: straw wreath

Dale: yeah

**TWO MINDS, ONE DIALOG: COORDINATING  
SPEAKING AND UNDERSTANDING**

Susan E. Brennan, Alexia Galati, and Anna K. Kuhlen

**People in dialogue seek and provide evidence for mutual understanding**

## Evidence used for grounding

- Can be explicit, such as a backchannel response (*uhuh*) or clarification question
- Can be implicit, such as displaying continuing attentiveness via eye contact or continuing with a next relevant utterance
- These paralinguistic cues provide information about the ongoing exchange itself, yet have been largely neglected by traditional models

People in dialogue seek and provide evidence for mutual understanding

# 1. Language games

Wittgenstein, Yo

# 2. Models of dialogue

Message model, interactive alignment, grounding

# 3. Conceptual pacts

Maze game, tangrams

# Maze game

A

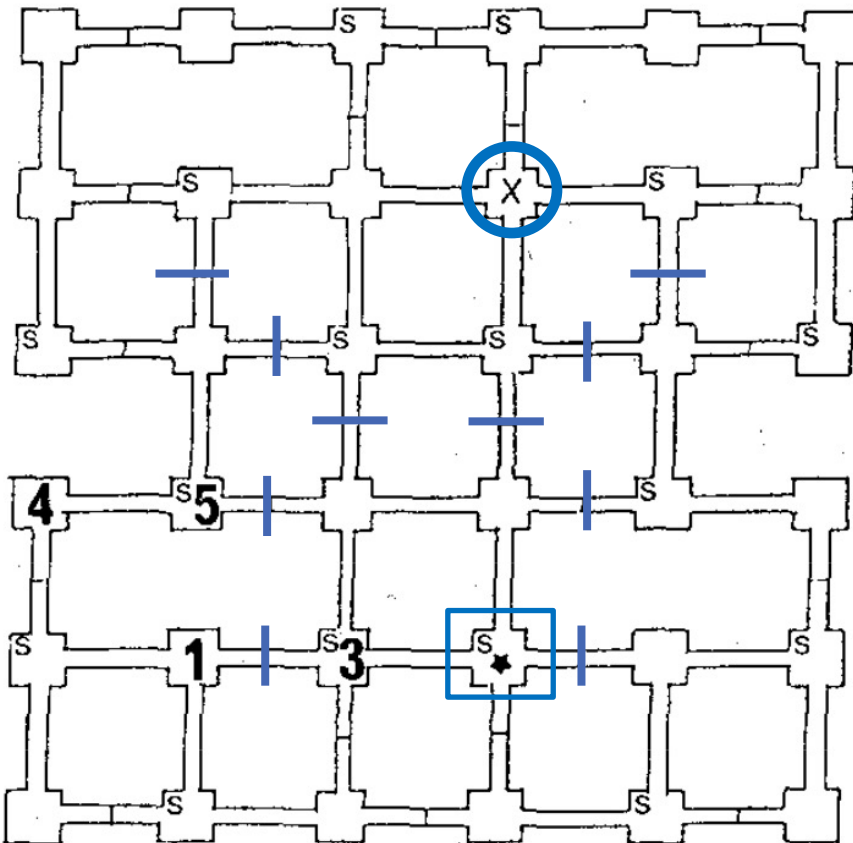

B

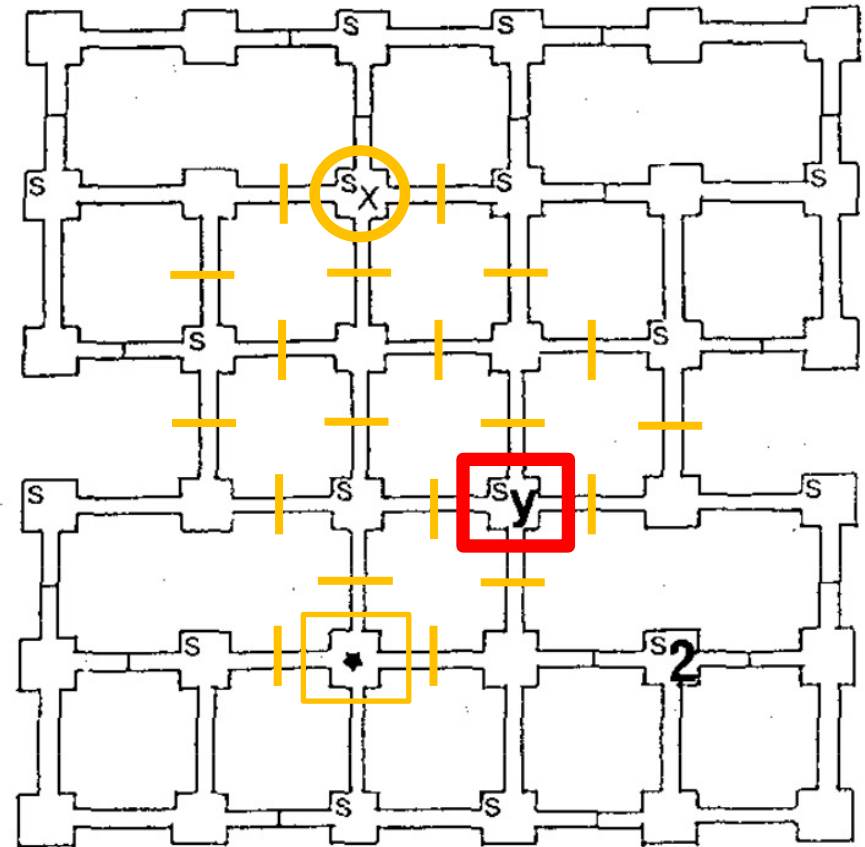

Path type: *"See the bottom right, go two along and two up"*

Saying what you mean in dialogue: A study in conceptual and semantic co-ordination\*

Coordinate type: *"I'm on the third row and fourth column"*

Line type: *"Third bottom line, third box from the right"*

# Tangrams



[A]



[B]



[C]



[D]

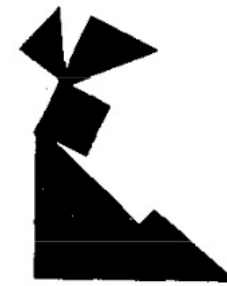

[E]



[F]

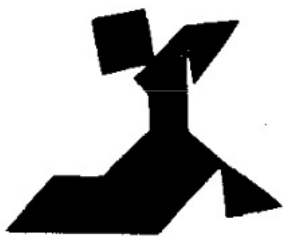

[G]



[H]



[I]



[J]



[K]



[L]

Referring as a collaborative process\*

# Tangrams

1. All right, the next one looks like a person who's ice skating, except they're sticking two arms out in front.

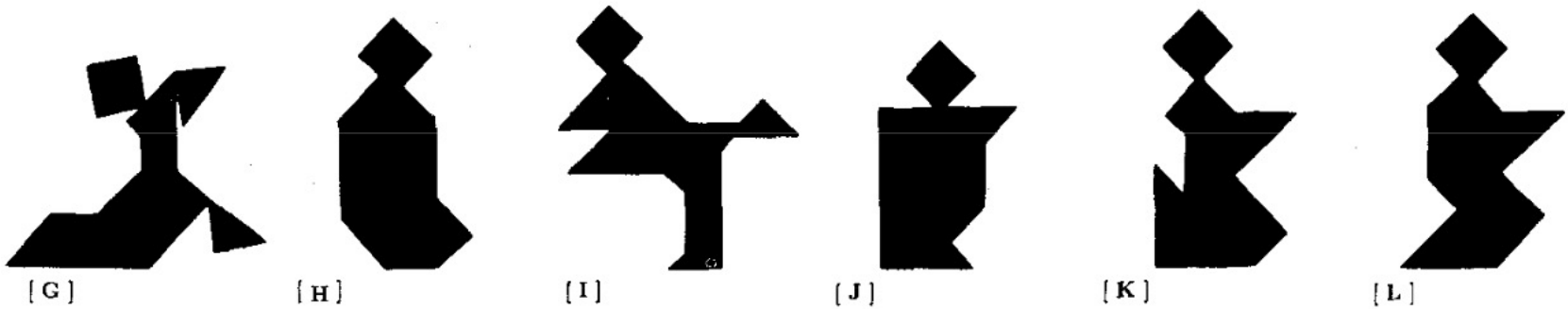

People in dialogue gradually simplify their (provisional) references

# Partner specificity

Conceptual Pacts and Lexical Choice in Conversation

Susan E. Brennan  
State University of New York at Stony Brook

Herbert H. Clark  
Stanford University

set A



set B



set C



Informativeness: "the shoe", regardless  
Recency: "the loafer", regardless  
Partner specificity: "the loafer" with same partner  
"the shoe" with new partner

**Lexical choice is based on partners and not informativeness or recency**

- Yo!?
- People collaboratively come to use the same terms in conversation
- They are “conceptual pacts”, provisional and partner-specific references to an object



- Measuring Mutual Understanding



